

OPERATIONAL PLAN

Balmertown, Cochenour & McKenzie Island
Drinking Water System

Madsen Drinking Water System

Red Lake Drinking Water System

Revision 8

Table of Contents

DWQMS Matrix	3
1 Quality Management System	5
2 Quality Management System Policy	5
3 Commitment and Endorsement.....	5
4 QMS Representative.....	6
5 Document & Records Control.....	6
6 Drinking-Water System	6
7 Risk Assessment	23
8 Risk Assessment Outcomes	23
9 Organizational Structure, Roles, Responsibilities and Authorities	24
10 Competencies.....	24
11 Personnel Coverage	24
12 Communications	24
13 Essential Supplies and Services	24
14 Review and Provision of Infrastructure.....	24
15 Infrastructure Maintenance, Rehabilitation, & Renewal	25
16 Sampling, Testing & Monitoring	26
17 Measurement and Recording Equipment Calibration and Maintenance	26
18 Emergency Management.....	27
19 Internal Audits.....	27
20 Management Review	27
21 Continual Improvement.....	27
22 Revision History.....	28

DWQMS Matrix

The DWQMS Matrix provided below indicates how the PLAN requirements of Ontario's DWQMS are addressed by Northern Waterworks Inc. DWQMS Elements are addressed through a combination of documentation which includes Operational Plans, corporate procedures and system-specific procedures. This matrix is intended to facilitate the understanding of the reader with respect to the structure of NWI's QMS. Additionally, this matrix will act to facilitate internal and external auditing processes.

DWQMS Element	Document Title
1 – Quality Management System	Operational Plan [RL-OP]
2 – QMS Policy	Operational Plan [RL-OP]
3 – Commitment and Endorsement	Operational Plan [RL-OP]
4 – QMS Representative	QMS Representative Policy [NWI-QMS-4]
5 – Document & Records Control	Document & Records Control Procedure [NWI-QMS-5]
6 – Drinking-Water System	Operational Plan [RL-OP]
7 – Risk Assessment	Risk Assessment Procedure [NWI-QMS-7]
8 – Risk Assessment Outcomes	Risk Assessment Outcomes – BCMI [BCMIDWS-QMS-8] Risk Assessment Outcomes – Madsen [MDWS-QMS-8] Risk Assessment Outcomes – Red Lake [RIDWS-QMS-8]
9 – Organizational Structure, Roles, Responsibilities and Authorities	Organizational Structure, Roles, Responsibilities and Authorities [NWI-QMS-9]
10 – Competencies	Competencies Policy [NWI-QMS-10]
11 – Personnel Coverage	Personnel Coverage Policy [NWI-QMS-11]
12 – Communications	QMS Communication Procedure [NWI-QMS-12]
13 – Essential Supplies and Services	Essential Supplies and Services Procedure [NWI-QMS-13]

DWQMS Element	Document Title
14 – Review and Provision of Infrastructure	Review and Provision of Infrastructure Procedure [NWI-QMS-14]
15 – Infrastructure Maintenance, Rehabilitation and Renewal	Operational Plan [RL-OP]
16 – Sampling, Testing and Monitoring	Sampling, Testing and Monitoring Procedure – BCMI [BCMIDWS-QMS-16] Sampling, Testing and Monitoring Procedure – Madsen [MDWS-QMS-16] Sampling, Testing and Monitoring Procedure – Red Lake [RLDWS-QMS-16]
17 – Measurement and Recording Equipment Calibration and Maintenance	Measurement and Recording Equipment Calibration and Maintenance Procedure [NWI-QMS-17]
18 – Emergency Management	Emergency Management Procedure [NWI-QMS-18]
19 – Internal Audits	Internal Audit Procedure [NWI-QMS-19]
20 – Management Review	Management Review Procedure [NWI-QMS-20]
21 – Continual Improvement	Continual Improvement Procedure [NWI-QMS-21]

1 Quality Management System

The Drinking Water Quality Management System (QMS) for the Balmertown, Cochenour & McKenzie Island (BCMI), Madsen & Red Lake Drinking Water Systems is documented in this Operational Plan as part of NWI's efforts to ensure that clean, safe and reliable drinking water is supplied to all customers served by these systems. The development and continual improvement of the Operational Plan will help to ensure that all regulatory requirements are met and that consumers can be confident that their drinking water will be protected through the effective application of the QMS. This Operational Plan was developed to meet the Ministry's Drinking Water Quality Management Standard.

2 Quality Management System Policy

The Corporation of the Municipality of Red Lake utilizes the services of Northern Waterworks Inc. (NWI), an independent contracted operating authority, to operate, maintain and manage the three (3) drinking water systems (as per agreement). The Municipality of Red Lake and Northern Waterworks Inc. are committed to the following:

- 1) Providing the consumer with clean, safe drinking water.
- 2) Meeting or exceeding all applicable legislative and regulatory requirements; and,
- 3) Maintaining and continually improving our quality management system.

3 Commitment and Endorsement

The Municipality of Red Lake and Northern Waterworks Inc. (NWI) support the implementation, maintenance and continual improvement of a Quality Management System for the BCMI, Madsen & Red Lake Drinking Water Systems, as documented in this Operational Plan. The Municipality and NWI acknowledge the need for and support the provision of sufficient resources to maintain and continually improve the QMS. For the purposes of the QMS, the persons in the undersigned authorized positions shall represent the Municipality of Red Lake as the system Owner and NWI as the accredited operating authority, respectively. The undersigned hereby endorse this Operational Plan:

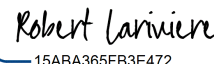
Name & Title:	Signature:	Date:
Trilbee Stirling-Kattler CPA, CGA Chief Administrative Officer The Municipality of Red Lake	Signed by:  E890C0A942BC496...	19 August 2024 06:16 EDT
Robert Lariviere Chief Operating Officer Northern Waterworks Inc.	Signed by:  15ABA365FB3E472...	21 August 2024 13:54 PDT

Endorsement of the QMS shall be updated when there are changes to the Operational Plan (OP) document or the authorized representative positions. New signatures are not required when the person in an authorized signatory position changes

4 QMS Representative

Refer to the *QMS Representative Policy* [NWI-QMS-4].

5 Document & Records Control

Refer to the *Document and Records Control Procedure* [NWI-QMS-5].

6 Drinking-Water System

6.1 Balmertown, Cochenour & McKenzie Island Drinking Water System

6.1.1 System Overview

The BCMI Drinking Water System provides a potable water supply to the communities of Balmertown, Cochenour and McKenzie Island. The system is composed of a raw water pumping station, the Cochenour Water Treatment Plant (CWTP, a Class III chemically assisted conventional filtration water treatment plant having a rated capacity of 6,065 m³/day), the Balmertown Reservoir Pumping Station, the Cochenour & McKenzie Island water distribution system, and the Balmertown water distribution system. The BCMI DWS is owned by the Corporation of the Municipality of Red Lake and Northern Waterworks Inc. serves as the accredited operating authority.

The source water for the treatment process is drawn from a surface water source (Bruce Channel, Red Lake) located within the Municipality. Potential pathogenic organisms are removed from the raw water by coagulation, flocculation, sedimentation, dual-media filtration, and free chlorine disinfection processes. This multiple barrier approach helps to ensure consistently safe and clean drinking water.

6.1.2 Source Water Characteristics and Event-Driven Fluctuations

General characteristics for the source water supply are provided in the table below.

Parameter ¹	Result Ranges (January 1, 2011 – August 31, 2022)
Turbidity (NTU)	0.48 – 2.07
UV Transmittance (%)	29.3 – 48.7
pH	6.8 – 7.5
Alkalinity (mg/L as CaCO ₃)	18 – 29
E. Coli (MPN/100mL)	<1 – 36
Total Coliforms (MPN/100mL)	<1 – >2420

1. Turbidity, UV transmittance, pH and alkalinity results are expressed as monthly averages.

Event-driven fluctuations in the source water and subsequent operational challenges are summarized as follows:

- (1) Seasonal changes in water temperature may impact treatment performance as it concerns chemically assisted filtration and disinfection processes. Higher water temperatures are also associated with increased biological activity in the source water, resulting in high turbidity, colour, micro-organism counts, and the potential for taste and odour problems.

Generally, seasonal changes pose only minor operational challenges, and these challenges can be anticipated and may require adjustments to treatment processes or chemical dosages.

- (2) Several potential pollution sources from nearby or upstream land use activities are known to affect Bruce Channel. There is a significant amount of activity on Bruce Channel, including float plane and boat activity, ferry service between Cochenour and McKenzie Island, its use as an ice road in the winter, the previous presence of drilling barges for mining exploration activities, the presence of a public beach, etc. There also exist upstream mining activities, and the surrounding area is well known for its gold mining activity. The area is susceptible to natural bacteriological contamination by wildlife.

An unnamed creek also discharges into Bruce Channel downstream of the drinking-water intake. This creek serves as the discharge watercourse for 1) treated effluent seasonally discharged from the Cochenour Lagoon, 2) treated effluent originating from an industrial arsenic removal water treatment facility and 3) supernatant created by conditioning process wastewater at the Cochenour WTP. Although geographically downstream, there is evidence that discharge from the creek affects water quality at the location of the intake. Specifically, a historical event that involved a collapsed manhole and caused the discharge of raw sewage into the creek resulted in an observable deterioration in the microbiological quality of the source water during the event.

Monitoring processes (e.g., routine or additional regulatory sampling and water quality testing, continuous monitoring), control measures (including normal treatment barriers) and contingency plans are available to minimize the operational challenges posed by a source water contamination event.

- (3) Algal blooms in the source water pose a potential concern, whereby such events could interfere with treatment processes and associated toxins may pose a risk of treated water contamination. Monitoring processes, control measures and contingency plans are available to minimize the operational challenges posed by algal blooms.

6.1.3 Treatment Processes

6.1.3.1 Source Water Intake & Pumping

Source water is obtained from Bruce Channel, Red Lake. The intake structure is located approximately 110 m from the shoreline adjacent to the raw water pumping station in the community of Cochenour. Water flows by gravity from the source and through the intake structure and the 300 mm diameter by 135 m long intake pipe into the raw water well at the raw water pumping station. From the wet well, three vertical turbine low lift pumps are available to transfer water directly to the package treatment units at the Cochenour Water Treatment Plant. The required rate of flow is determined by community demand.

6.1.3.2 Coagulation, Flocculation and Sedimentation

The three (3) package treatment units at the water treatment facility operate in parallel and each have a rated capacity of 2,125 m³/day. Each unit includes a three-chambered flocculation basin, a sedimentation basin (clarifier) equipped with upflow tube settlers, and a dual-media filter. A coagulant (aluminum sulphate) and a pre-treatment alkalinity adjustment chemical (sodium carbonate) are added to and rapidly mixed with the incoming raw water upstream from the flocculation basins.

The coagulated water solution then enters the flocculation basins of the respective treatment units, where gentle mixing promotes the formation of floc. A flocculant (polymer) is also added to the water at this stage of treatment to form larger and more stable floc aggregates. Process water then enters the clarifier, where its velocity is reduced to allow for the separation and settling of floc. Supernatant then overflows into effluent launders and is directed to the filter unit. Settled floc (sludge) is automatically removed from the bottom of the sedimentation basin.

6.1.3.3 Filtration

Impurities that were not captured and settled as floc in the sedimentation basin are removed by passing water through a dual media filter composed of anthracite and silica sand. Filtered water passes through the filter under-drain system and is directed to the treated water storage reservoirs. The filters are periodically cleaned by using an air scour to agitate the entire media bed and reversing the flow of water through the filter using dedicated backwash pumps.

6.1.3.4 Disinfection

Chlorine gas is used to achieve both primary and secondary disinfection at the Cochenour Water Treatment Plant. Primary disinfection ensures that any potentially pathogenic organisms that remain after previous treatment processes are destroyed or inactivated.

To achieve primary disinfection, a super-chlorinated solution is applied to the filtrate upstream from the treated water storage reservoirs. Consistent disinfection is ensured by the continuous monitoring of the disinfectant residual in treated water leaving the facility.

Secondary disinfection requirements are achieved by adding enough chlorine at the water treatment plant to maintain a free chlorine residual throughout the respective distribution systems. The purpose of this procedure is to prevent the growth of biofilm within the distribution system and to protect the water from re-contamination as it flows through the community.

6.1.3.5 pH Adjustment

The primary coagulant used at the Cochenour WTP reduces the pH of the water, and a pH/alkalinity adjustment chemical (sodium carbonate) is added to the filtrate as it is directed to the treated water storage reservoir. Increasing the pH of finished water at the facility helps to prevent corrosion in the water distribution systems.

6.1.3.6 Treated Water Storage and Delivery

Following the application of disinfectant and pH adjustment chemicals, two constant speed vertical turbine pumps are used to transfer water through a transmission line from the Cochenour Water Treatment Plant to the reservoir at the Balmertown Reservoir Pumping Station (RPS). Primary disinfection is achieved as disinfectant mixes with the water in the reservoirs at each facility.

At the Cochenour Water Treatment Plant, filtered water is directed to a two-cell treated water underground storage reservoir with a total volume of 1,179 m³. A total of four (4) vertical turbine high lift pumps are available to transfer finished water from the reservoir to the Cochenour and McKenzie Island water distribution system. The high lift pumps are equipped with variable frequency drive motor controllers to maintain pressure and supply in the distribution system. Operation of the high lift pumps is controlled by a pressure switch located on the distribution header inside the water treatment plant.

At the Balmertown RPS, filtered water is transferred to a treated water underground storage reservoir with a total volume of 2,238 m³. A total of four (4) variable speed vertical turbine high lift pumps are available to transfer finished water from the reservoir to the Balmertown water distribution system.

6.1.3.7 Emergency Power and Instrumentation

The raw water pumping station, Cochenour WTP and Balmertown RPS each include a standby diesel generator for supplying emergency power.

The Cochenour WTP and Balmertown RPS include programmable logic controllers complete with SCADA systems for process monitoring and control. Critical process

instruments include one (1) raw water flow measuring device, three (3) filtrate turbidity analyzers, two (2) treated water flow measuring devices (one at the CWTP, one at the BRPS) and two (2) treated water free chlorine residual analyzers for monitoring primary disinfection (one at the CWTP, one at the BRPS).

6.1.3.8 Process Waste Residuals Management

Process wastewater generated from water treatment processes is managed at the Cochenour WTP. Sludge discharge, backwash wastewater and filter-to-waste wastewater are directed to the sludge holding tank (also referred to as the backwash surge tank or surge tank). Using a submersible pump, process wastewater is then transferred from the sludge holding tank to the thickening tank (also referred to as the backwash thickening tank, thickening tank or decant tank). Upon transfer, a flocculant (polymer) is added to condition the sludge for settling. After sludge has settled in the thickening tank, the supernatant is returned to Bruce Channel. Thickened sludge is periodically removed by pumping it to the sanitary sewer system. Alternatively, thickened sludge may be removed by pumping it to a truck for haulage and disposal at a designated disposal site.

6.1.4 Distribution System Components

6.1.4.1 Cochenour & McKenzie Island Water Distribution System

The Cochenour & McKenzie Island water distribution system is a standalone distribution system that consists of approximately 9.2 km of watermain and 33 hydrants, with associated watermain and hydrant isolation valves. The most common watermain sizes consist of between 75 mm to 200 mm diameter piping. The system includes a submerged line that extends between Cochenour and McKenzie Island.

6.1.4.2 Balmertown Water Distribution System

The Balmertown water distribution system is a standalone system that consists of approximately 8.8 km of watermain and 45 hydrants, with associated watermain and hydrant isolation valves. The system includes watermains made from ductile iron, cast iron, and asbestos-concrete materials; the majority of watermains consist of 150 mm or 200 mm diameter pipes.

6.1.5 Process Flow Diagram

A process flow diagram for the system is provided on the following page.

Balmertown, Cochenour & McKenzie Island Drinking Water System Process Flow Diagram

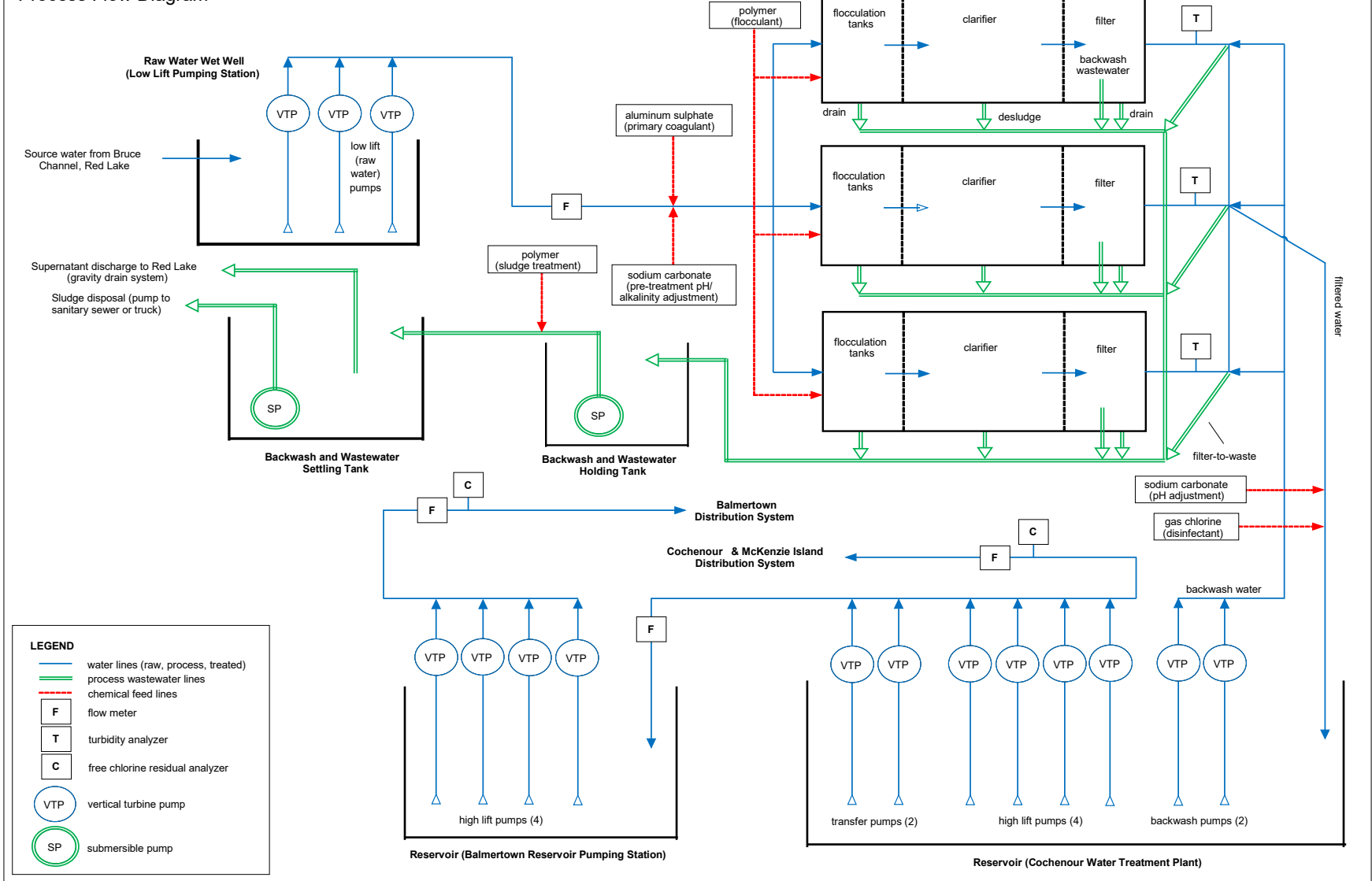

Revision Date: 9 August 2024
Revision Level: 8
Internal Reference: RL-OP
Page 11 of 29



6.2 Madsen Drinking Water System

6.2.1 System Overview

The Madsen Drinking Water System provides a potable water supply to the community of Madsen and is composed of a raw water pumping station, the Madsen Water Treatment Plant (MWTP, a Class III chemically-assisted conventional filtration system water treatment plant having a rated capacity of 691 m³/day) and a water distribution system (a Class I system). The Madsen DWS is owned by the Corporation of the Municipality of Red Lake and Northern Waterworks Inc. serves as the accredited operating authority.

The source water for the treatment process is drawn from a surface water source (Russett Lake) located within the Municipality. Potential pathogenic organisms are removed from the raw water by pre-oxidation, coagulation, flocculation, sedimentation, dual-media filtration, and disinfection processes. This multiple barrier approach helps to ensure consistently safe and clean drinking water.

6.2.2 Source Water Characteristics and Event-Driven Fluctuations

General characteristics for the source water supply are provided in the table below.

Parameter ¹	Result Ranges (January 1, 2011 – August 31, 2022)
Turbidity (NTU)	0.29 - 2.07
UV Transmittance (%)	50.3 – 65.1
pH	6.4 - 7.6
Alkalinity (mg/L as CaCO ₃)	27 - 38
Iron Residual (mg/L)	0.01 - 0.16
Manganese Residual (mg/L)	0.02 - 0.21
E. Coli (MPN/100mL)	<1 - 14
Total Coliforms (MPN/100mL)	<1 - >2420
1. Turbidity, UV transmittance, pH, alkalinity, iron residual and manganese residual results are expressed as monthly averages.	

Event-driven fluctuations in the source water and subsequent operational challenges are summarized as follows:

- (1) Reduced forms of iron and manganese present in the source water have historically been responsible for elevated treated water turbidity and colour, particularly in warmer water temperatures. The operational challenges posed by such fluctuations are minimized by using a preoxidation process (potassium permanganate). This process effectively oxidizes iron and manganese present in source water, and the

precipitated forms are removed by the downstream chemically assisted conventional filtration process.

Changes in the concentrations of the reduced forms of iron and manganese in the source water may require slight adjustments to treatment (preoxidation) chemical dosages.

- (2) Seasonal changes in water temperature may impact treatment performance as it concerns chemically assisted filtration and disinfection processes. Higher water temperatures are also associated with increased biological activity in the source water, resulting in high turbidity, colour, micro-organism counts, and the potential for taste and odour problems.

Generally, seasonal changes pose only minor operational challenges, and these challenges can be anticipated and may require adjustments to treatment processes or chemical dosages.

- (3) A limited number of potential pollution sources are known to affect Russett Lake. The area is influenced by some recreational activities and is susceptible to natural bacteriological contamination by wildlife. Mining and exploration activities adjacent to Russett Lake are also potential pollution sources.

Monitoring processes (e.g., routine or additional regulatory sampling and water quality testing, continuous monitoring), control measures (including normal treatment barriers) and contingency plans are available to minimize the operational challenges posed by a source water contamination event.

- (4) Algal blooms in the source water pose a potential concern, whereby such events could interfere with treatment processes and associated toxins may pose a risk of treated water contamination.

Monitoring processes, control measures and contingency plans are available to minimize the operational challenges posed by algal blooms.

6.2.3 Treatment Processes

6.2.3.1 Source Water Intake & Pumping

Source water is obtained from Russett Lake. The intake structure is located approximately 30 m from the shoreline adjacent to the raw water pumping station. Water flows from the source and through the intake structure and 300 mm diameter HDPE intake pipe and is pumped directly from the raw water pumping station to the Madsen WTP. Water is transferred using two constant speed centrifugal raw water pumps via a 150 mm diameter HDPE transmission line.

At the treatment facility, an oxidizing agent is added to the source water as it enters the dual baffled raw water reservoirs (with a total volume of 99 m³). Two constant speed centrifugal pumps are then used to transfer water from the raw water reservoirs directly to the treatment units. The transfer of raw water from

Russett Lake to the raw water reservoirs occurs in response to the water level in the raw water reservoir, such that the flow of raw water stops when the water level in the reservoir reaches an upper set point.

6.2.3.2 Coagulation, Flocculation and Sedimentation

The two (2) package treatment units at the water treatment facility operate in parallel and each have a rated capacity of 345.6 m³/day. Each unit includes a three-chambered flocculation basin, a sedimentation basin (clarifier) equipped with upflow tube settlers, and a dual-media filter. A coagulant (polyaluminum chloride) is added to and rapidly mixed with the incoming raw water upstream from the flocculation basins.

The coagulated water solution then enters the flocculation basins of the respective treatment units, where gentle mixing promotes the formation of floc. A flocculant (polymer) is also added to the water at this stage of treatment to form larger and more stable floc aggregates. Process water then enters the sedimentation basin, where its velocity is reduced to allow for the separation and settling of floc. Supernatant then overflows into effluent launders and is directed to the filter unit. Settled floc (sludge) is automatically removed from the bottom of the sedimentation basin.

6.2.3.3 Filtration

Impurities that were not captured and settled as floc in the sedimentation basin are removed by passing water through a dual media filter composed of anthracite and silica sand. Filtered water passes through the filter under-drain system and is directed to the treated water storage reservoirs. The filters are periodically cleaned by using an air scour to agitate the entire media bed and reversing the flow of water through the filter using dedicated backwash pumps.

6.2.3.4 Disinfection

Sodium hypochlorite is used to achieve both primary and secondary disinfection at the Madsen Water Treatment Plant. Primary disinfection ensures that any potentially pathogenic organisms that remain after previous treatment processes are destroyed or inactivated.

To achieve primary disinfection, sodium hypochlorite is applied to the filtrate upstream from the treated water storage reservoirs. Consistent disinfection is ensured by the continuous monitoring of the disinfectant residual in treated water leaving the facility.

Secondary disinfection requirements are achieved by adding enough chlorine at the water treatment plant to maintain a free chlorine residual throughout the water distribution system. The purpose of this procedure is to prevent the growth of biofilm within the distribution system and to protect the water from re-contamination as it flows through the community.

6.2.3.5 pH Adjustment

The primary coagulant used at the Madsen WTP reduces the pH of the water, and a pH/alkalinity adjustment chemical (sodium carbonate) is added to the filtrate as it is directed to the treated water storage reservoir. Increasing the pH of finished water at the facility helps to prevent corrosion in the water distribution system.

6.2.3.6 Treated Water Storage and Delivery

Following the application of disinfectant and pH adjustment chemicals, filtrate is directed to a two-cell underground baffled storage reservoir with a total volume of 190 m³. Disinfected water is then held in the reservoir for enough time to achieve primary disinfection.

Each cell includes a pump well, and a total of four (4) vertical turbine high lift pumps are available to transfer finished water from the reservoir to the Madsen water distribution system. The high lift pumps are equipped with variable frequency drive motor controllers to maintain pressure and supply in the distribution system. Operation of the high lift pumps is controlled by a pressure switch located on the distribution header inside the water treatment plant.

6.2.3.7 Emergency Power and Instrumentation

The Madsen WTP includes a standby diesel generator for supplying emergency power.

The Madsen WTP includes a PLC complete with a SCADA system for process monitoring and control. Critical process instruments include one (1) raw water flow measuring device, one (1) raw water transfer flow measuring device, two (2) filtrate turbidity analyzers, one (1) treated water flow measuring device, and (1) one treated water free chlorine residual analyzer for monitoring primary disinfection.

6.2.3.8 Process Waste Residuals Management

Process wastewater generated from water treatment processes is managed at the Madsen WTP. Sludge discharge, backwash wastewater, and rinse-to-waste wastewater are directed to the sludge holding tank (also referred to as the backwash surge tank or surge tank). Using a submersible pump, process wastewater is then transferred from the sludge holding tank to the thickening tank (also referred to as the backwash thickening tank, thickening tank, or decant tank). From the thickening tank, process wastewater is pumped directly to the Madsen sanitary sewer system.

6.2.4 Distribution System Components

The Madsen distribution system consists of approximately 2.6 km of watermain; the majority of watermains are 100 mm diameter HDPE pipes. The system is looped and includes 4 hydrants and associated watermain and hydrant isolation valves.

6.2.5 Process Flow Diagram

A process flow diagram for the system is provided on the following page.

Madsen Drinking Water System Process Flow Diagram

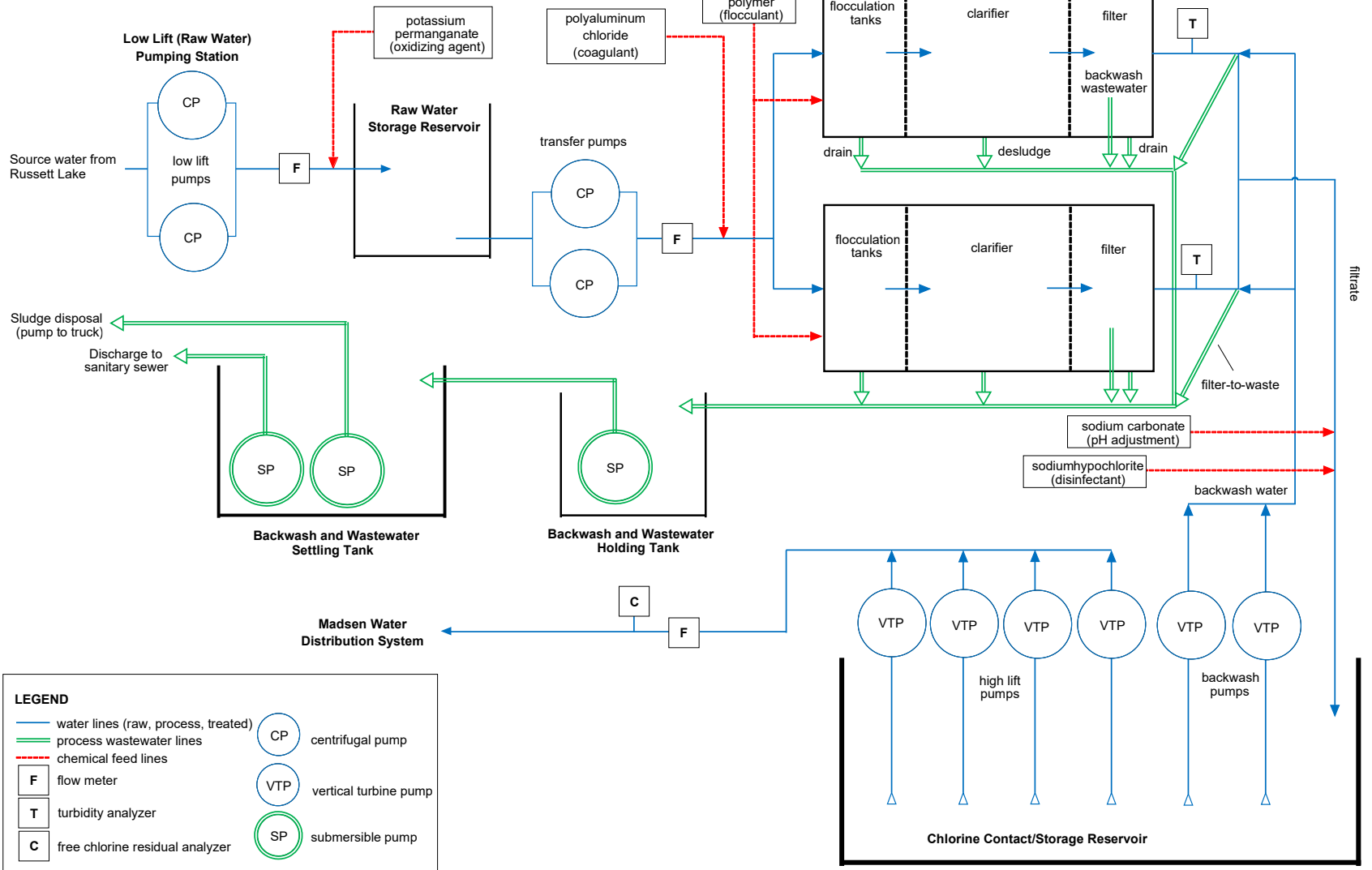

Revision Date: 9 August 2024
 Revision Level: 8
 Internal Reference: RL-OP
 Page 17 of 29



6.3 Red Lake Drinking Water System

6.3.1 System Overview

The Red Lake Drinking Water System provides a potable water supply to the community of Red Lake and is composed of the Red Lake Water Treatment Plant (RLWTP, a Class III chemically-assisted conventional filtration water treatment plant having a rated capacity of 6,048 m³/day), the Red Lake water tower and the Red Lake water distribution system (a Class I water distribution system). The Red Lake DWS is owned by the Corporation of the Municipality of Red Lake and Northern Waterworks Inc. serves as the accredited operating authority.

The source water for the treatment process is drawn from a surface water source (Skookum Bay, Red Lake) located within the Municipality. Potential pathogenic organisms are removed from the raw water by coagulation, flocculation, sedimentation, dual-media filtration, and free chlorine disinfection processes. This multiple barrier approach helps to ensure consistently safe and clean drinking water.

6.3.2 Source Water Characteristics and Event-Driven Fluctuations

General characteristics for the source water supply are provided in the table below.

Parameter ¹	Result Ranges (January 1, 2011 – August 31, 2022)
Turbidity (NTU)	0.33 – 1.68
UV Transmittance (%)	41.1 – 53.4
pH	6.4 – 7.6
Alkalinity (mg/L as CaCO ₃)	17 – 29
E. Coli (MPN/100mL)	<1 – 23
Total Coliforms (MPN/100mL)	<1 – 2420

1. Turbidity, UV transmittance, pH and alkalinity results are expressed as monthly averages.

Event-driven fluctuations in the source water and subsequent operational challenges are summarized as follows:

- (1) Seasonal changes in water temperature may impact treatment performance as it concerns chemically assisted filtration and disinfection processes. Higher water temperatures are also associated with increased biological activity in the source water, resulting in high turbidity, colour, micro-organism counts, and the potential for taste and odour problems.

Generally, seasonal changes pose only minor operational challenges, and these challenges can be anticipated and may require adjustments to treatment processes or chemical dosages.

- (2) A limited number of potential pollution sources are known to affect Skookum Bay. The area is influenced by recreational activities and is susceptible to natural bacteriological contamination by wildlife.

Monitoring processes (e.g., routine or additional regulatory sampling and water quality testing, continuous monitoring), control measures (including normal treatment barriers) and contingency plans are available to minimize the operational challenges posed by a source water contamination event.

- (3) Algal blooms in the source water pose a potential concern, whereby such events could interfere with treatment processes and associated toxins may pose a risk of treated water contamination. Monitoring processes, control measures and contingency plans are available to minimize the operational challenges posed by algal blooms.

6.3.3 Treatment Processes

6.3.3.1 Source Water Intake & Pumping

The intake structure for the Red Lake Water Treatment Plant is located approximately 610 meters north/northwest of the building in Skookum Bay, Red Lake, at an approximate depth of 14 meters. Water flows by gravity from the source and through the intake structure and 400 mm diameter cast iron intake pipe into two (2) interconnected low lift (raw water) pump wells located at the treatment plant. Three vertical turbine low lift pumps are available to transfer water from the pump wells directly to the package treatment units. The required rate of flow is determined by community demand.

6.3.3.2 Coagulation, Flocculation and Sedimentation

The two (2) package treatment units at the water treatment facility operate in parallel and each have a rated capacity of 3,024 m³/day. Each unit includes a four-chambered flocculation basin, a sedimentation basin (clarifier) equipped with upflow tube settlers, and a dual-media filter. A coagulant (aluminum sulphate) and a pre-treatment alkalinity adjustment chemical (sodium carbonate) are added to and rapidly mixed with the incoming raw water upstream from the flocculation basins.

The coagulated water solution then enters the flocculation basins of the respective treatment units, where gentle mixing promotes the formation of floc. A flocculant (polymer) is also added to the water at this stage of treatment to form larger and more stable floc aggregates. Process water then enters the sedimentation basin, where its velocity is reduced to allow for the separation and settling of floc. Supernatant then overflows into effluent launders and is directed to the filter unit. Settled floc (sludge) is automatically removed from the bottom of the sedimentation basin.

6.3.3.3 Filtration

Impurities that were not captured and settled as floc in the sedimentation basin are removed by passing water through a dual media filter composed of anthracite and silica sand. Filtered water passes through the filter under-drain system and is directed to the treated water storage reservoirs. The filters are periodically cleaned by using an air scour to agitate the entire media bed and reversing the flow of water through the filter.

6.3.3.4 Disinfection

Chlorine gas is used to achieve both primary and secondary disinfection at the Red Lake Water Treatment Plant. Primary disinfection ensures that any potentially pathogenic organisms that remain after previous treatment processes are destroyed or inactivated.

To achieve primary disinfection, a super-chlorinated solution is applied to the filtrate upstream from the treated water storage reservoirs. Consistent disinfection is ensured by the continuous monitoring of the disinfectant residual in treated water leaving the facility.

Secondary disinfection requirements are achieved by adding enough chlorine at the water treatment plant to maintain a free chlorine residual throughout the water distribution system. The purpose of this procedure is to prevent the growth of biofilm within the distribution system and to protect the water from re-contamination as it flows through the community.

6.3.3.5 pH Adjustment

The primary coagulant used at the Red Lake WTP reduces the pH of the water, and a pH/alkalinity adjustment chemical (sodium carbonate) is added to the filtrate as it is directed to the treated water storage reservoir. The Red Lake Drinking Water System also adheres to a *Corrosion Control Plan* to control lead release in residential and non-residential plumbing, and the use of a pH/alkalinity adjustment chemical is required to ensure that finished water pH is consistently maintained between 7.6 and 8.0.

6.3.3.6 Treated Water Storage and Delivery

Following the application of disinfectant and pH adjustment chemicals, filtrate is directed to two (2) interconnected underground storage reservoirs with a total volume of 563 m³. Disinfected water is then held in the reservoir for enough time to achieve primary disinfection.

Each reservoir includes a pump well, and a total of four (4) vertical turbine high lift pumps are available to transfer finished water from the reservoirs to the Red Lake water tower and distribution system. The operation of the high lift pumps and transfer to the water tower are controlled by a water level indicator at the tower.

6.3.3.7 Emergency Power and Instrumentation

The Red Lake WTP includes a standby diesel generator for supplying emergency power.

The Red Lake WTP also includes a programmable logic controllers complete with SCADA system for process monitoring and control. Critical process instruments include one (1) raw water flow measuring device, two (2) filtrate turbidity analyzers, one (1) treated water flow measuring device, and one combination treated water pH and free chlorine residual analyzer for monitoring primary disinfection.

6.3.3.8 Process Waste Residuals Management

Process wastewater generated from water treatment processes is managed at the Red Lake WTP. Sludge discharge, backwash wastewater and filter-to-waste wastewater are directed to the sludge holding tank (also referred to as the backwash surge tank or surge tank). Using a submersible pump, process wastewater is then transferred from the sludge holding tank to the thickening tank (also referred to as the backwash thickening tank, thickening tank or decant tank). Upon transfer, a flocculant (polymer) is added to condition the sludge for settling. After sludge has settled in the thickening tank, the supernatant is returned to Skookum Bay. Thickened sludge is periodically removed by pumping it to a truck for haulage and disposal at a designated disposal site.

6.3.4 Distribution System Components

Treated water enters the distribution system and is transferred to the Red Lake water tower. The tower has a total volume of 1,465 m³ and is used to regulate system pressure, in addition to providing a reserve volume of water for emergency situations.

The Red Lake water distribution system consists of approximately 20.8 km of watermain and 122 hydrants, with associated watermain and hydrant isolation valves. The most common watermain materials consist of ductile iron, HDPE, and cast iron; the most common watermain sizes consist of between 150 mm to 250 mm diameter piping.

6.3.5 Process Flow Diagram

A process flow diagram for the system is provided on the following page.

Red Lake Drinking Water System Process Flow Diagram

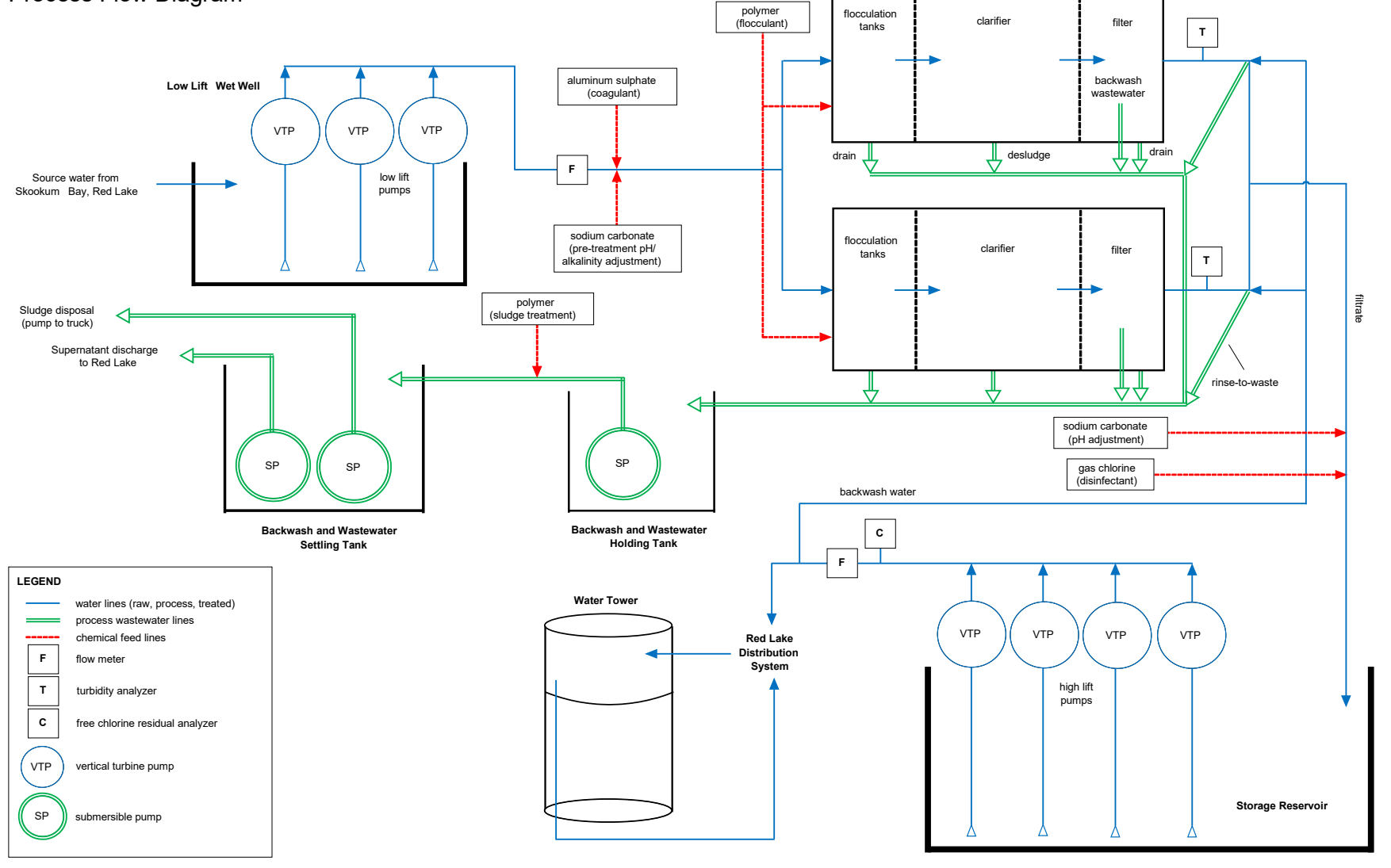

Revision Date: 9 August 2024
 Revision Level: 8
 Internal Reference: RL-OP
 Page 22 of 29



7 Risk Assessment

Refer to the *Risk Assessment Procedure* [NWI-QMS-7].

8 Risk Assessment Outcomes

8.1 Interpretation of the Risk Assessment Outcomes

The risk assessment outcomes were developed using the *Risk Assessment Procedure* [NWI-QMS-7]. This procedure contains all the information necessary to interpret the *Risk Assessment Outcomes* for the respective drinking water systems. The risk assessment outcomes include the following:

- (1) Potential hazardous events and associated hazards.
- (2) Assessed risks associated with the occurrence of hazardous events, including considering the likelihood, severity and detectability of the event.
- (3) Ranked hazardous events.
- (4) Monitoring processes and control measures associated with each hazardous event.
- (5) Critical control points and their respective critical control limits; and,
- (6) Response procedures for hazardous events.

8.2 Monitoring Critical Control Limits

Various monitoring processes are in place to monitor critical control limits and to identify deviations from those limits. Critical control limits and other parameters associated with critical control limits are monitored by the following processes:

- (1) Continuous monitoring and alarm systems (e.g., analyzers and trending associated with free chlorine residual data, flow, pressure, etc.). Alarm systems notify operators when critical control limits or other alarm set points have been breached.
- (2) Routine regulatory sampling (e.g., weekly microbiological analyses, quarterly chemical analyses, etc.).
- (3) Routine water quality testing (e.g., daily tests for free chlorine, turbidity and pH, etc.).
- (4) Operational checks, where operators collect and interpret data (e.g., pump operating hours, flows, analyzer readings, compliance data, etc.) and inspect facilities daily.
- (5) Additional operational checks associated with planned maintenance, where certified operators conduct more detailed monthly inspections of facilities and,

- (6) Notification from external parties (e.g., notification that a chemical contamination event has occurred, notification of a large fire in the community, a water quality complaint that results in the identification of a cross-connection, etc.).

8.3 Critical Control Limit Deviations

Procedures outlining how to respond to, report and record deviations from critical control limits exist as a series of *Emergency Response Procedures* (contingency plans). Specifically, *Emergency Response Procedures* contain step-by-step response instructions, including instructions related to communication protocols and recordkeeping requirements.

All critical control limit deviations are recorded in the facility logbook but may also be recorded within Adverse Water Quality Incident documentation, call-out records, customer complaint records and operational spreadsheets.

9 Organizational Structure, Roles, Responsibilities and Authorities

Refer to the *Organizational Structure, Roles, Responsibilities & Authorities Policy* [NWI-QMS-9].

10 Competencies

Refer to the *Competencies Policy* [NWI-QMS-10].

11 Personnel Coverage

Refer to the *Personnel Coverage Policy* [NWI-QMS-11].

12 Communications

Refer to the *QMS Communication Procedure* [NWI-QMS-12].

13 Essential Supplies and Services

Refer to the *Essential Supplies and Services Procedure* [NWI-QMS-13].

14 Review and Provision of Infrastructure

Refer to the *Review and Provision of Infrastructure Procedure* [NWI-QMS-14].

15 Infrastructure Maintenance, Rehabilitation, & Renewal

15.1 Planned Maintenance, Rehabilitation, & Renewal

NWI, under contract with the owner, maintains a program of scheduled inspection and maintenance of infrastructure for which it is operationally responsible. Maintenance activities are developed according to manufacturer instructions, regulatory requirements, industry standards and/or client service requirements. Records of planned maintenance activities are controlled in accordance with NWI's *Document and Records Control Procedure* [NWI-QMS-5]. The major components of the infrastructure maintenance, rehabilitation and renewal programs in place for the respective drinking water systems are described below.

- (1) The *Planned Maintenance Activities* Standard Operating Procedure documents a comprehensive program that is conducted by operations staff on a monthly or less frequent basis. This procedure dictates planned inspection and maintenance activities associated with infrastructure components including pumps, valves, chemical feed systems, treatment equipment, emergency response equipment, standby power systems, heating systems, lighting and other components necessary to ensure a reliable supply of safe drinking-water.

This procedure also facilitates infrastructure rehabilitation and renewal, as it requires the identification and reporting of deficiencies. Identified deficiencies may be addressed through operational budgets, particularly as it concerns the rehabilitation and renewal of smaller infrastructure components.

- (2) The *Measurement and Recording Equipment Calibration and Maintenance Procedure* documents certain planned calibration and maintenance activities that are specific to instrumentation. The associated *Calibration and Maintenance Records* are used to indicate a variety of maintenance activities, such as instrument inspection, cleaning and quality assurance. Generally, such activities are carried out by operations staff on a monthly basis.
- (3) The water distribution systems are flushed, and hydrants are operated and inspected on an annual basis. Major distribution system and hydrant deficiencies identified during this program are used to plan for future maintenance activities.
- (4) NWI monitors and coordinates additional maintenance activities that include infrastructure inspection, maintenance or servicing that occur on a recurring but less frequent basis. Examples of such activities include flow meter calibration verification, backflow prevention device testing, reservoir cleaning and inspections, thermal imaging inspections, emergency generator servicing and load testing, the replacement of various critical components, etc.
- (5) The annual infrastructure review and budgeting processes are the main methods through which infrastructure rehabilitation and renewal occurs. Specifically, the outcomes of the infrastructure review represent the main inputs into annual capital expenditure budgets prepared by NWI for consideration and approval by the

Municipality of Red Lake. The integration of annual budgeting and infrastructure review processes represents a continuous and cohesive effort to identify deficiencies and plan for infrastructure rehabilitation and renewal.

15.2 Unplanned Maintenance

Unplanned maintenance tasks related to the drinking water system treatment components result from equipment or infrastructure failures. Unplanned maintenance is authorized by the Operations Manager or the Overall Responsible Operator. Documentation of these unplanned maintenance tasks are recorded in the facility logbooks. Measures to prepare for and expedite unplanned maintenance tasks in these scenarios include equipment interchangeability and redundancy, spare parts inventories, and the availability of relevant operations and maintenance manuals.

Unplanned maintenance tasks, infrastructure repair and renewal related to distribution system components are typically performed by the Municipality of Red Lake, in conjunction with representation from Northern Waterworks Inc. Measures to prepare for and expedite unplanned maintenance tasks include the cataloguing of the distribution system, maintaining a parts inventory, and having access to repair procedures.

15.3 Program Monitoring

To ensure that the planned maintenance program remains effective, the *Planned Maintenance Activities SOP* and the *Measurement and Recording Equipment Calibration and Maintenance Procedure* are reviewed and updated annually. This review is facilitated by Compliance and includes Operations Managers and Operators. The review accounts for changes to infrastructure and allows an opportunity to refine and continually improve the maintenance program, particularly as it involves incorporating new best practices.

15.4 Program Communication

NWI's infrastructure maintenance, rehabilitation and renewal programs are communicated to the Municipality of Red Lake on annual basis as a component of the communication of management review results. Significant planned and unplanned infrastructure maintenance, rehabilitation and renewal activities are also described in monthly operational reports submitted to the Municipality.

16 Sampling, Testing & Monitoring

Refer to the *Sampling, Testing, & Monitoring Procedures* for the Balmertown, Cochenour & McKenzie Island Drinking Water System [BCMIDWS-QMS-16], Madsen Drinking Water System [MDWS-QMS-16] and the Red Lake Drinking Water System [RLDWS-QMS-16].

17 Measurement and Recording Equipment Calibration and Maintenance

Refer to the *Measurement and Recording Equipment Calibration and Maintenance Procedure* [NWI-QMS-17].

18 Emergency Management

Refer to the *Emergency Management Procedure* [NWI-QMS-18].

19 Internal Audits

Refer to the *Internal Audit Procedure* [NWI-QMS-19].

20 Management Review

Refer to the *Management Review Procedure* [NWI-QMS-20].

21 Continual Improvement

Northern Waterworks Inc. is committed to continually improving the effectiveness of its Quality Management System. Continual improvement is facilitated by the management review and internal auditing processes, which include the identification of QMS deficiencies and the assignment of preventive and corrective actions.

Refer to the *Continual Improvement Procedure* [NWI-QMS-21].

22 Revision History

Date	Revision	Comments
1-Dec-2009	1	Initial publication of Operational Plan
1-Jul-2011	2	Revisions to address external audit results.
25-Jul-2012	3	Publication of new version following QMS restructuring.
25-Oct-2013	4	Section 3 (Commitment and Endorsement) was amended to include NWI's current Top Management with respect to the Standard.
29-Apr-2014	5	Updates to section 15 (Infrastructure Maintenance, Rehabilitation, and Renewal); section 13 (Essential Supplies and Services) removed following replacement with corporate procedure.
2-Apr-2018	6	Updates to sections 2 (QMS Policy), 3 (Commitment and Endorsement), 6 (Drinking-Water System), 8 (Risk Assessment Outcomes), 15 (Infrastructure Maintenance, Rehabilitation, and Renewal) and 21 (Continual Improvement).
28-Sep-2022	7	Updates to incorporate all systems into a multi-system Operational Plan. Updates to sections 3 (Commitment and Endorsement), 6 (Drinking-Water System), 8 (Risk Assessment Outcomes) & 15 (Infrastructure Maintenance, Rehabilitation, and Renewal).
9-Aug-2024	8	Updated to include new NWI Chief Operating Officer, Update to section 3 (Commitment and Endorsement)

**Schedule C – Director’s Directions for Operational Plans
(Subject System Description Form)
Municipal Residential Drinking Water System**

Fields marked with an asterisk (*) are mandatory.

Owner of Municipal Residential Drinking Water System *
The Corporation of the Municipality of Red Lake

Subject Systems

Name of Drinking Water System (DWS) *	Licence Number *	Name of Operating Subsystems (if applicable)	Name of Operating Authority *	DWS Number(s) *
1. Balmertown, Cochenour & McKenzie Island Drinking Water System	234-101		Northern Waterworks Inc.	220000950
2. Madsen Drinking Water System	234-102		Northern Waterworks Inc.	210001479
3. Red Lake Drinking Water System	234-103		Northern Waterworks Inc.	210000265

Contact Information for Questions Regarding the Operational Plan

Primary Contact

Last Name *	First Name *	Middle Initial
Happl	Jessica	
Title *	Telephone Number *	Email Address *
Manager QMS & Compliance	705-989-2045 ext.	jessica.happl@ssmpuc.com

Secondary Contact

Last Name	First Name	Middle Initial
Lariviere	Robert	
Title	Telephone Number	Email Address
Chief Operating Officer	807-728-0588 ext.	robert.lariviere@nwi.ca